

Description

BP2513D is Non-isolated CCCV driver IC. The device operates in discontinued conduction mode and is suitable for 85Vac~265Vac universal input offline LED lighting. The BP2513D integrates a 500V power MOSFET with constant current & constant voltage control engine. It can perform in high accurate CCCV without external compensation capacitor, benefit to save the BOM size and cost.

The BP2513D supports multiple control mode of PWM and PFM, which contribute to very low standby power, high efficiency and minimum no load noise.

The BP2513D offers rich protection functions to improve the system reliability, including cycle by cycle peak current control, load open/short protection, VCC under/over voltage protection, and over temperature protection.

Typical Application

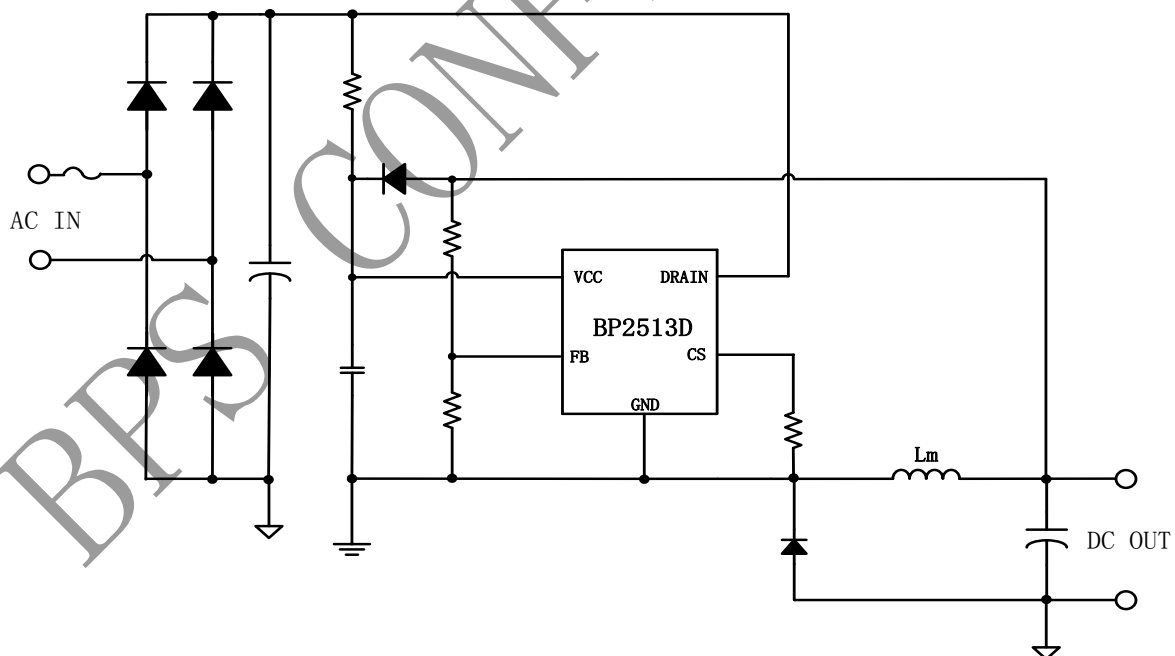

Fig1 Typical application circuit for BP2513D

Features

- Non-Isolated CCCV control
- PWM/PFM multiple mode control
- Internal 500V Power MOSFET
- Standby power <200mW
- ±5% Output Accuracy
- Internal soft startup
- Load open protection
- Load short protection
- VCC under voltage protection
- Over temperature protection
- Cycle by cycle peak current control
- SOP8 package

Applications

- Non-Isolated power
- Standby/auxiliary power
- LED driving model

Ordering Information

Part Number	Package	Operating Temperature	Packing Method	Marking
BP2513D	SOP8	-40°C to 105°C	Tape 4,000 pcs/Reel	BP2513D XXXXXY WWXY

Pin Configuration and Marking Information

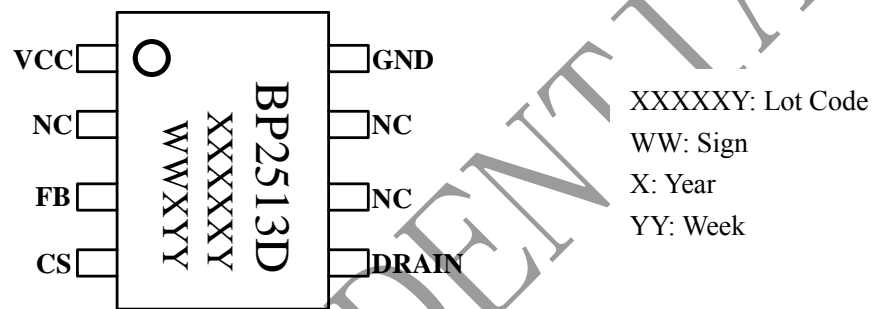

Fig2 Pin configuration

Pin Definition

Pin No.	Name	Description
1	VCC	Power Supply Pin
2,6,7	NC	NO connection
3	FB	Feedback pin
4	CS	Current Sense Pin. Connect a sense resistor between this pin and GND pin.
5	DRAIN	Internal HV Power MOSFET Drain.
8	GND	Ground

Absolute Maximum Ratings (note1)

Symbol	Parameters	Range	Units
V _{DS}	Internal HV MOSFET Drain to Source voltage	-0.3~500	V
V _{CC}	VCC pin voltage	-0.3~30	V
I _{CC_MAX}	VCC pin maximum sink current	10	mA
V _{FB}	Feedback Voltage detection Pin	-0.3~6	V
V _{CS}	Voltage on Current sense pin	-0.3~6	V
P _{DMAX}	Power dissipation (note2)	0.45	W
θ _{JA}	Thermal resistance (Junction to Ambient)	145	°C/W
T _J	Operating junction temperature	-40 to 150	°C
T _{STG}	Storage temperature range	-55 to 150	°C
	ESD (note3)	2	kV

Note 1: Stresses beyond those listed under “absolute maximum ratings” may cause permanent damage to the device. Under “recommended operating conditions” the device operation is assured, but some particular parameter may not be achieved. The electrical characteristics table defines the operation range of the device, the electrical characteristics is assured on DC and AC voltage by test program. For the parameters without minimum and maximum value in the EC table, the typical value defines the operation range, the accuracy is not guaranteed by spec.

Note 2: The maximum power dissipation decrease if temperature rise, it is decided by T_{JMAX}, θ_{JA}, and environment temperature (T_A). The maximum power dissipation is the lower one between P_{DMAX} = (T_{JMAX} - T_A) / θ_{JA} and the number listed in the maximum table.

Note 3: Human Body mode, 100pF capacitor discharge on 1.5kΩ resistor.

Recommended Operation Conditions

Symbol	Parameter	Range	Unit
V _{CC}	Supply voltage	10~ 25	V
F _{osc_MAX}	Max. operation frequency	100k	Hz

**Electrical Characteristics (Notes 4, 5) (Unless otherwise specified, $V_{CC}=16V$ and $T_A=25^\circ C$)**

Symbol	Parameter	Conditions	Min	Typ	Max	Units
Supply Voltage Section						
V_{CC_CLAMP}	V_{CC} Clamp Voltage	5mA		27		V
V_{CC_ON}	V_{CC} Turn On Threshold	V_{CC} Rising		15.3		V
V_{CC_UVLO}	V_{CC} Turn Off Threshold	V_{CC} Falling		7.6		V
I_{ST}	V_{CC} Startup Current	$V_{CC}=V_{CC_ON}-1V$		120		μA
I_{OP}	V_{CC} Operating Current	$V_{FB}=3V, V_{CS}=0$		240		μA
Current Sense Section						
V_{CS_TH}	CS Peak Threshold			600		mV
T_{LEB}	Leading Edge Blanking			350		ns
Feedback Section						
$V_{FB_EA_REF}$	Internal EA Reference Voltage			3		V
V_{FB_OVP}	FB OVP Threshold			4		V
V_{FB_DEM}	FB ZCD Threshold			0.1		V
V_{FB_SHORT}	Output short protection Threshold			0.5		V
F_{OSC_SHORT}	Clamp frequency for output short			20		kHz
T_{SAMPLE_BIG}	Samples time	$V_{CS_TH}=600mV$		5.8		μs
T_{OFF_MAX}	Max. OFF time	Guaranteed by design		1		ms
T_{ON_MAX}	Max. ON time			40		μs
Power MOSFET						
R_{DS_ON}	Static Drain-source On-resistance	$V_{GS}=10V/I_{DS}=0.5A$		10		Ω
BV_{DSS}	Drain-Source Breakdown Voltage	$V_{GS}=0V/I_{DS}=250\mu A$	500			V
I_{DSS}	Power MOSFET Drain Leakage Current	$V_{GS}=0V/V_{DS}=500V$			1	μA
Thermal Regulation Section						
T_{SD}	Thermal shunt down	Guaranteed by design		150		$^\circ C$

Note 4: production testing of the chip is performed at 25°C.

Note 5: the maximum and minimum parameters specified are guaranteed by test, the typical value are guaranteed by design, characterization and statistical analysis

Internal Block Diagram

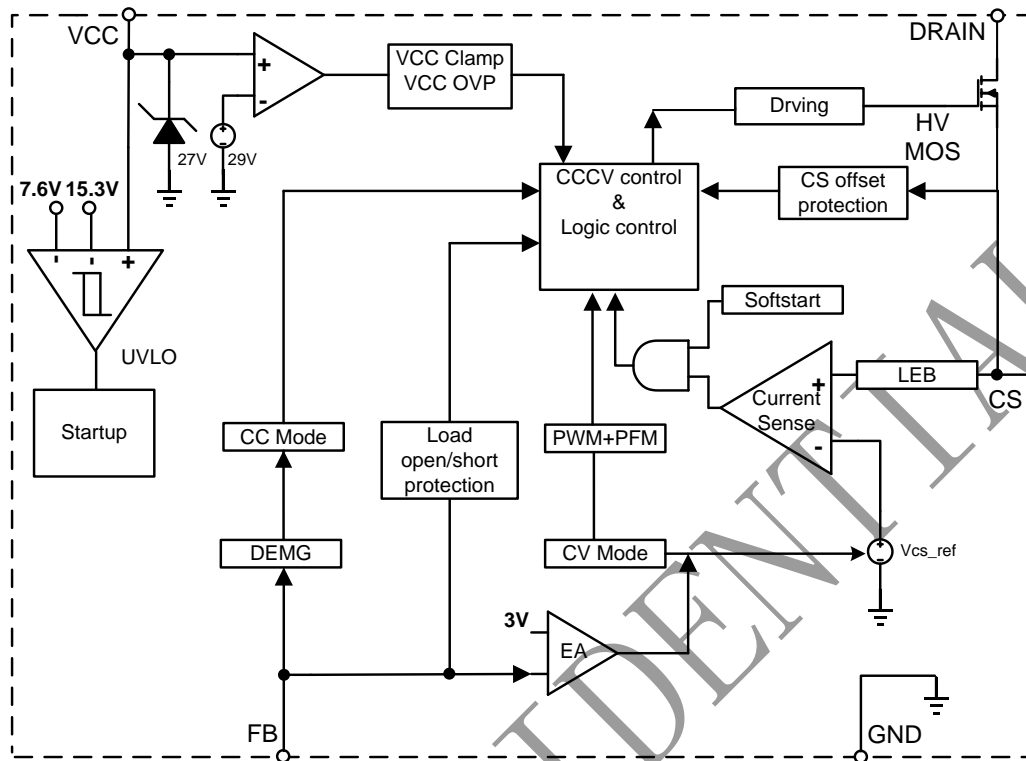

Fig3 BP2513D Internal Block Diagram

Application Information

BP2513D is primary side regulation isolated CCCV driver IC, operating in DCM mode. BP2513D can work in multiple control mode of PFM and PWM providing high accurate constant current control and constant voltage control. there is very few external components required in bill of material. BP2513D provides the popular solutions for chargers, standby power, LED drivers and any CCCV request.

Startup

After system powered on, BP2513D needs 120Ua startup current, the capacitor on VCC pin is charged up by the startup resistor. When the VCC pin voltage reaches the turn on threshold, the internal circuits start working. Once the start level has been reached the start-up current source is switched off. During switching operation it is supplied by the regulated source from output.

Soft start is also implemented during startup within

1ms timeslot, and activated to increase the primary side peak current in steps. The soft start is available in every restart cycle.

Constant Current Control

The peak current of primary side inductor is sensed cycle by cycle. The CS pin monitors the peak level and inputs into the internal comparator with converted voltage of the switching status; once the voltage above the reference threshold, the switching would be stopped.

The peak current for full load is defined as:

$$I_{P_PK} = \frac{600}{R_{CS}} (mA)$$

The peak detection has a fixed 350ns lead edge blanking time on CS.

The LED current is defined as:



$$I_{OUT} = \frac{I_{P-PK}}{2}$$

Constant Voltage Control

BP2513D senses the voltage on winding by divider resistor on FB pin. The constant output voltage is ensured by this sense voltage and internal reference in close loop.

The output voltage V_{out} is defined as:

$$V_{out} = \frac{3 * (R_{FBL} + R_{FBH})}{R_{FBL}}$$

Where,

R_{FBL} is pull high resistor on FB pin;

R_{FBH} is pull high resistor on FB pin.

Multiple mode control: PWM/PFM

BP2513D is to use multiple mode control to improve the performance on efficiency, standby power, and audible noise in low load condition.

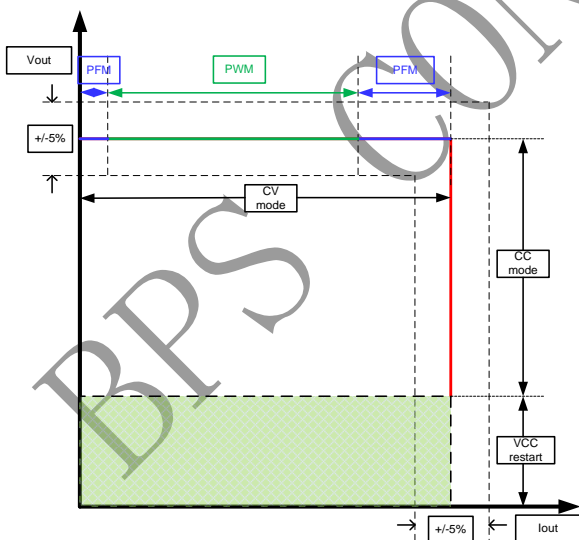

system reliability, including output overvoltage protection, load short protection, Vcc under voltage lock out protection, over temperature protection.

This sense voltage on FB is also serve for load over voltage protection. The detection threshold is 4V on FB, and the V_{ovp} defined as:

$$V_{OVP} = \frac{4V * (R_{FBL} + R_{FBH})}{R_{FBL}}$$

Where V_{ovp} is the design expectation on OVP.

When the sense voltage on FB is under 0.5V, as default the system would open guard for short protection and operating frequency clamped to 20kHz, which could save the stress on MOSFET. The system will restart after 48ms timeout.

During any fault condition, the Vcc voltage would be discharged. As well the Vcc voltage under UVLO threshold, the system will restart till shift to normal condition once the fault condition removed.

Protections

BP2513D offers rich protections to improve the



PCB Design Guide

Suggestions for PCB layout of BP2513D application:

1. Bypass Capacitor on Vcc:

The bypass capacitor on V_{CC} pin should be as close as possible to the V_{CC} Pin and GND pin.

2. Divider resistor for FB pin

Put the divider resistor close to the FB pin as possible, and keep the trace away to the switching node.

3. GND

Keep a short and wide ground path for current sense resistor, especially for the main current loop. The IC signal ground for FB components should be connected to the IC GND.

4. NC pins

Set Pin6 and Pin7 offset to keep the safety space.

5. The Area of Power Loop

The area of main current loop should be as small as possible to reduce EMI radiation.

BPS

CONFIDENTIAL

Package

